

DV-QIHB(T300-H)

4M QHD 네트워크 IR 불릿 카메라



A. 제품특성

- 열화상 256 x 192 디텍터, 12 μ m
- 열감도 : < 40mK(25°C, F1.0)
- 2688 x 1520, 1/2.7" Progressive Scan CMOS
- DDE, AGC, 3D DNR
- 온도 탐지 범위 -20°C to 150°C (-4°F to 302°F), 정확도 \pm 8°C (\pm 14.4°F)
- 0.0089Lux @(F1.6, AGC ON), 0 Lux with IR
- POE (802.3af, class 3) 지원

B. 외관도

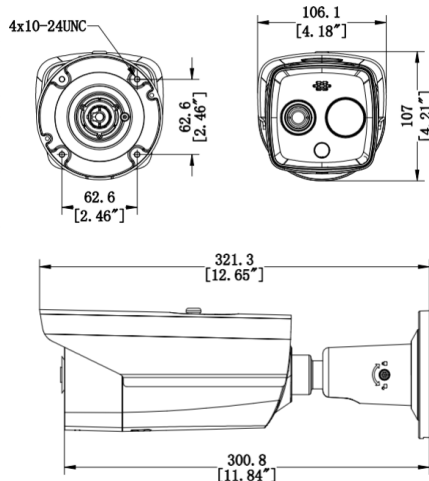

C. 제품 사양

Camera	
Sensor	1/2.7" Progressive Scan CMOS, 2688 x 1520
조도	0.0089Lux @(F1.6, AGC ON), 0 Lux with IR
Shutter	1 s to 1/100,000 s
Focal Length	4.3 mm

열화상 모듈	
촬상소자	Vanadium Oxide Uncooled Focal Plane Arrays, 256 x 192, 12 μ m Pixel Pitch
파장	8 μ m - 14 μ m
열감도/NETD	< 40 mK (25°C, F1.0)
Focal Length	3.6
Field of View	50.0°(H) x 37.3°(V)
Digital zoom	x2, x4

IR 및 온도 알람	
IR Distance	Up to 30 m
IR Intensity and Angle	Automatically adjusted
온도 알람	10 포인트, 10 영역, 1 라인
온도 탐지 범위	-20°C to 150°C (-4°F to 302°F)
온도 정확도	\pm 8°C (\pm 14.4°F)

Network	
Protocols	IPv4/IPv6, HTTP, HTTPS, 802.1x, Qos, FTP, SMTP, UPnP, SNMP, DNS, DDNS, NTP, RTSP, RTP, TCP, UDP, IGMP, ICMP, DHCP, PPPoE, Bonjour, SFTP, SRTP
Network Storage	MicroSD/SDHC/SDXC card (up to 256 GB) local storage, NAS (NFS, SMB/CIFS), Auto Network Replenishment (ANR)
메인 스트리밍	Thermal 25 fps (1280 x 720, 704 x 576, 640 x 512, 320 x 240) Optical 50 Hz: 25 fps (2688 x 1520, 1920 x 1080, 1280 x 720) 60 Hz: 30 fps (2688 x 1520, 1920 x 1080, 1280 x 720)
서브 스트리밍	Thermal 25 fps (704 x 576, 640 x 512, 320 x 240) Optical 50 Hz: 25 fps (704 x 576, 352 x 288) 60 Hz: 30 fps (704 x 480, 352 x 240)

Interface	
Alarm I/O	2 alarm-in (0 to 5 VDC), 2 alarm-out(alarm response actions configurable)
Audio Input	1, 3.5 mm Mic in/Line in interface Line input: 2 to 2.4 V [p-p], output impedance: 1 K Ω \pm 10%
Audio Output	Linear level, impedance: 600 Ω
이더넷 포트	1, RJ45 10 M/100 M Self-adaptive Ethernet interface. 1, RS-485 interface (half duplex)

General	
소비전력	24 VAC \pm 25%, 12 VDC \pm 25%, two-core terminal block PoE (802.3af, class 3)
사용환경	온도: -40°C to 65°C (-40°F to 149°F), 습도: 95% or less
방수방진 등급	IP67 Standard
Dimensions (Ø x H)	321.3 mm x 106.1 mm x 107.0 mm
Weight	1550g (3.41 lb)